



# SHiFT<sup>®</sup>

## MODULUS

Care and Maintenance  
Manual

# M06

Bolted  
Plastic  
Pumps



## Performance Curve

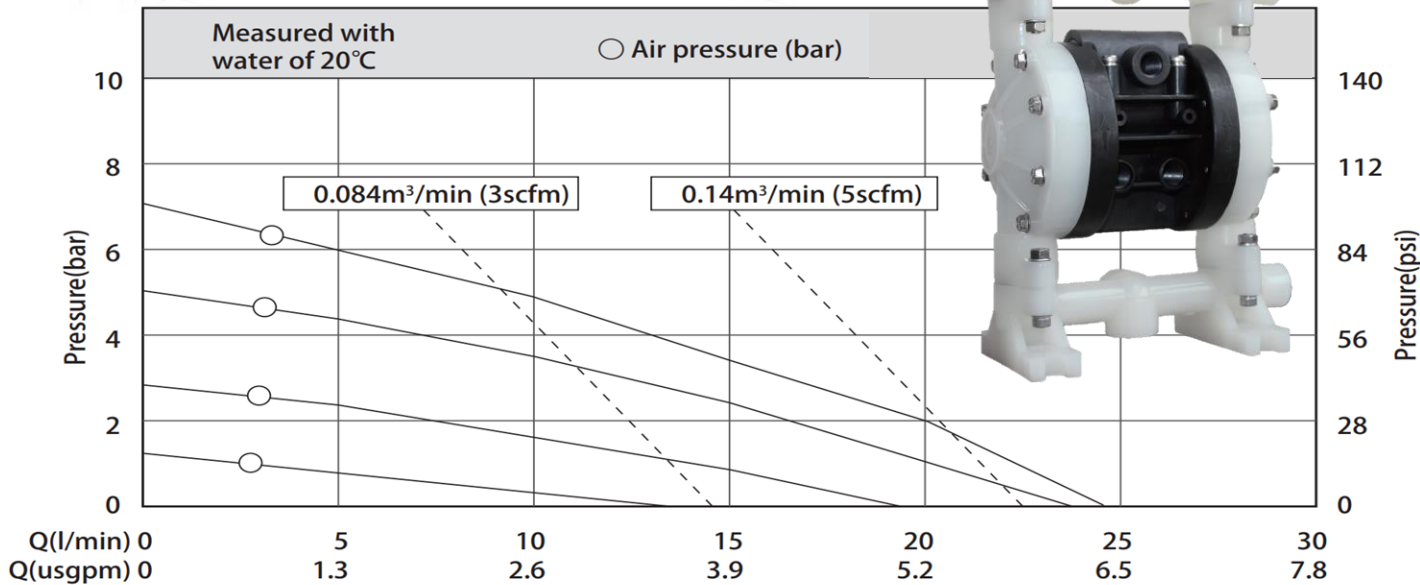

## Technical Parameters

Parameter	Unit	Value
Suction Lift - dry	mwc	2.1
Suction lift - wet	mwc	3.7 – 6.4
Solids size	mm	1.6
Air inlet	inch	¼
Max air inlet pressure	bar	7

## Material of Construction

Pump Part	Material
Pump body	PP, PVDF
Diaphragm	Santoprene (ST), Teflon (TF), Hytrel
Seat	PP, PVDF
Centre block	PP

## Weight

Pump type	Weight
Polypropylene	1.5kg
PVDF	2kg

# Dimensional Drawings

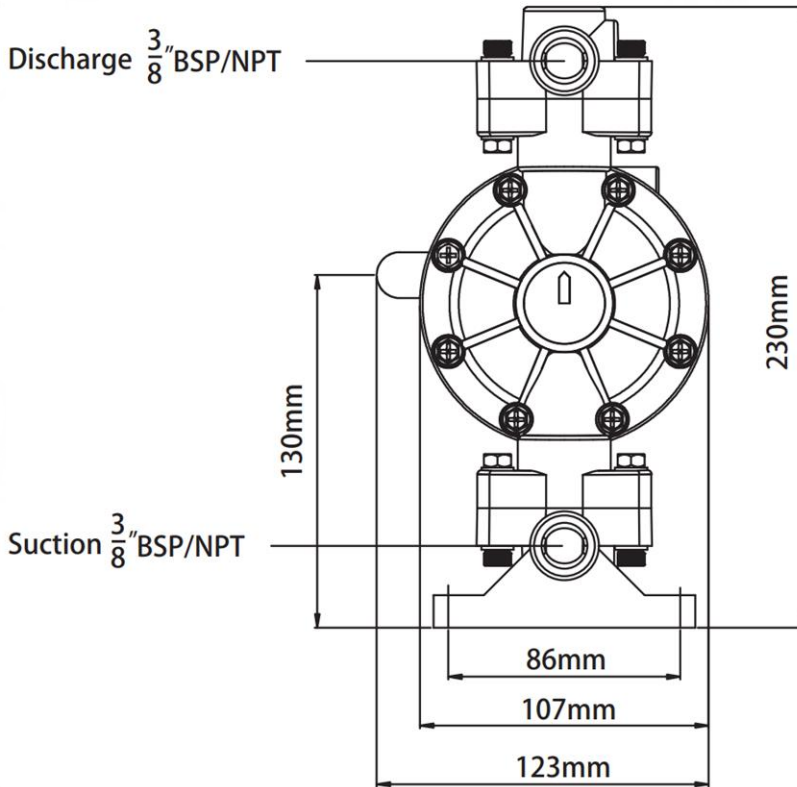
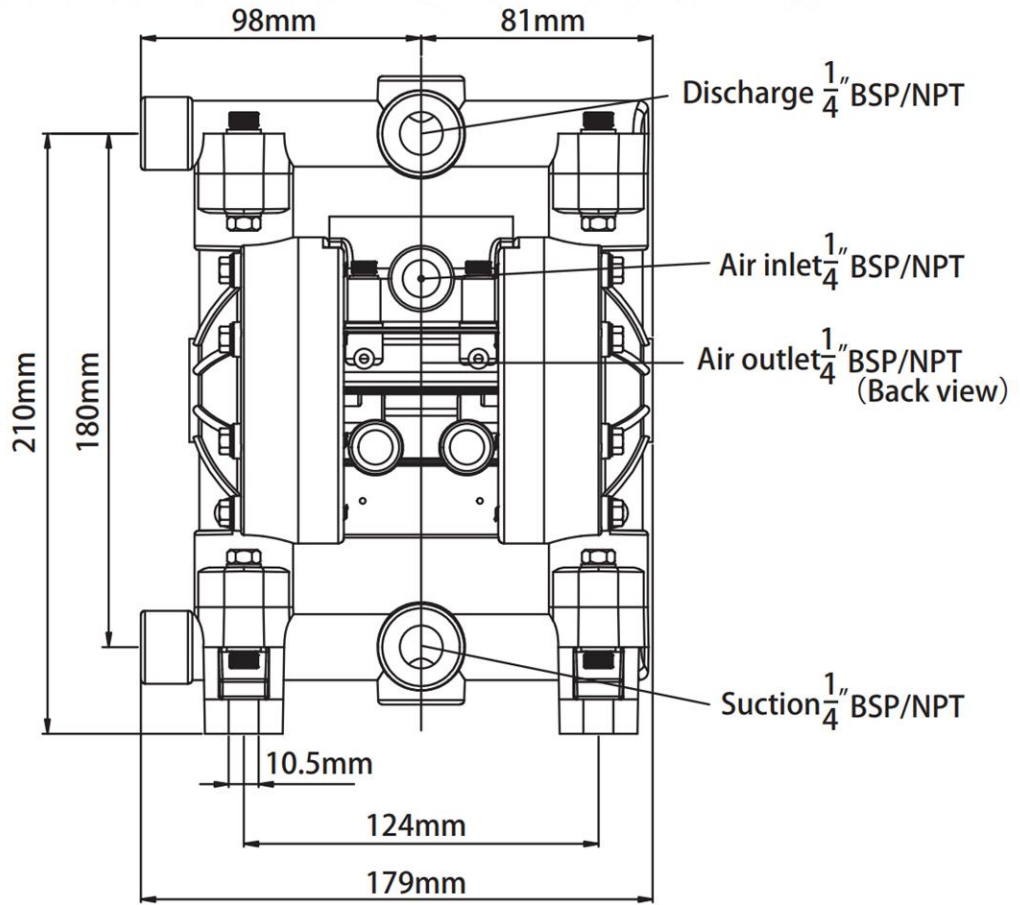

# Part Numbers

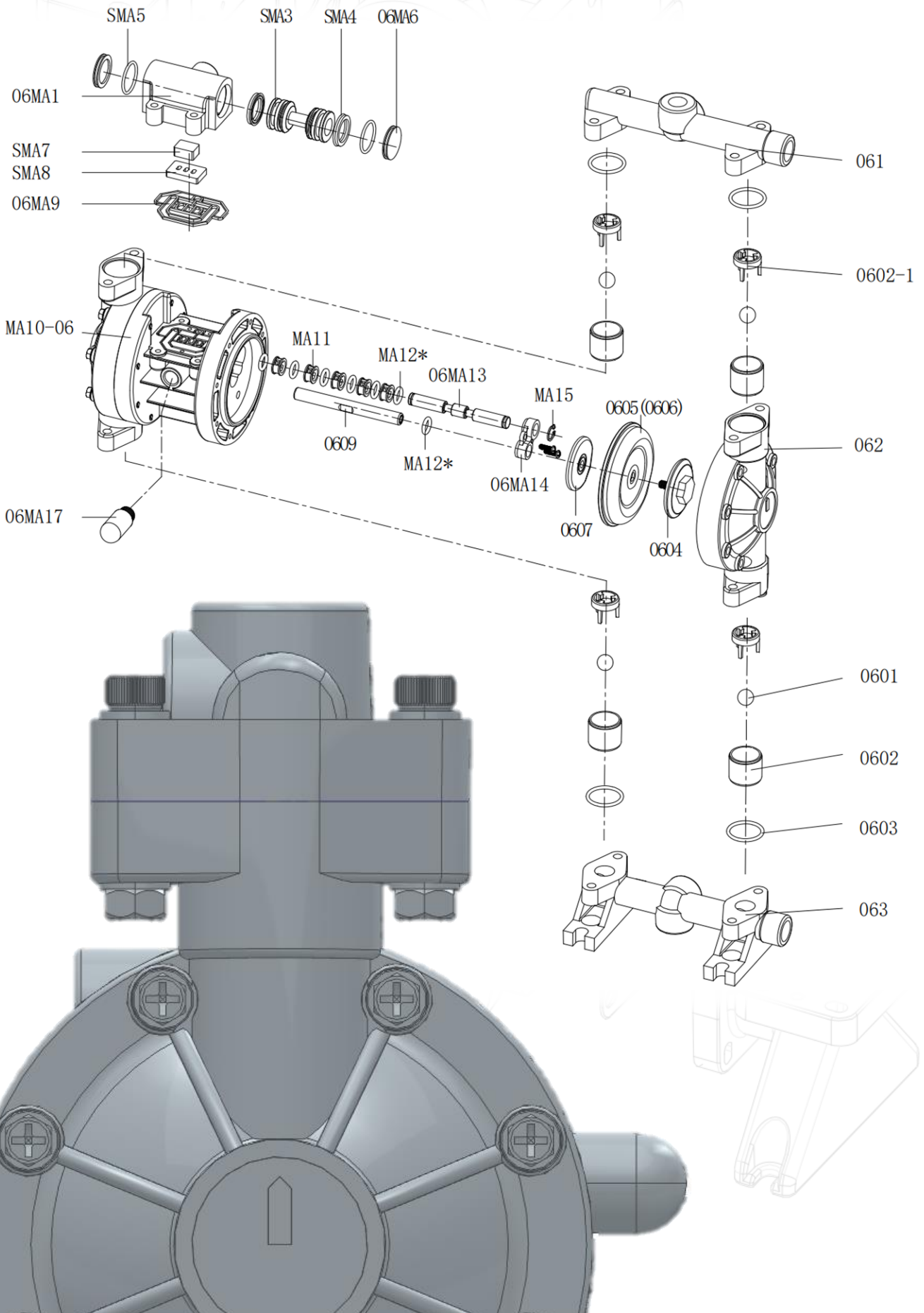

## Part Numbers

Part code	Name
06MA1-KV	Air valve housing
SMA3-PM	Piston
SMA4-VT	Piston V-ring
SMA5-VT	Plug O-ring
06MA6-KV	Plug
SMA7-CM	Pilot valve
SMA8-CM	Valve plate
06MA9-ST	Air valve gasket

Part code	Name
MA10-06-PP	Center block
MA11-PM	Reversing valve
MA12-VT	Shaft O-ring
06MA13-SS	Reversing shaft
06MA14-PP	Locking plate
MA15-SS	Snap ring
06MA17-PE	Muffler

Part code	Name
061-PP	Discharge manifold
061-AL	
061-KV	
061-SS	
061-LL	
062-PP	
062-AL	Fluid chamber
062-KV	
062-SS	
062-LL	
063-PP	
063-AL	
063-KV	Suction manifold
063-SS	
063-LL	
0601-TF	Valve ball
0601-SS	
0601-LL	
0602-PP	Valve seat
0602-KV	
0602-SS	
0602-LL	

Part code	Name
0602-1-PP	Baffle
0602-1-KV	
0602-1-SS	
0602-1-LL	Seat O-ring
0603-TF	
0603-BN	
0603-EP	
0603-VT	
0604-PP	
0604-KV	Plate
0604-SS	
0604-LL	
0605-TF	Teflon diaphragm
0606-ST	Rubber diaphragm
0606-HY	
0606-BN	
0606-EP	
0606-VT	
0607-SS	Inner plate
0609-SS	Diaphragm rod

SMA3,4,5,7,8 of MK06, MK15 are the same, MA11,12,15 of all PP centre block are the same Rod O-ring of MK06 also same as MA12

The background of the entire page is a technical line drawing of a complex mechanical assembly, likely a pump or motor. The drawing is rendered in a light blue color and is centered on the page. It shows various components such as a central shaft, bearings, housing, and mounting brackets. The drawing is a cross-sectional view, showing the internal structure of the machine. The top half of the drawing is partially obscured by a dark grey rounded rectangle containing the text 'MODULUS RANGE'.

# MODULUS

RANGE

Powered by:  **TAQS**  
INDUSTRIES