



SHiFT[®]

MODULUS

Data Sheet

Full
Flow
High
Pressure
Pumps

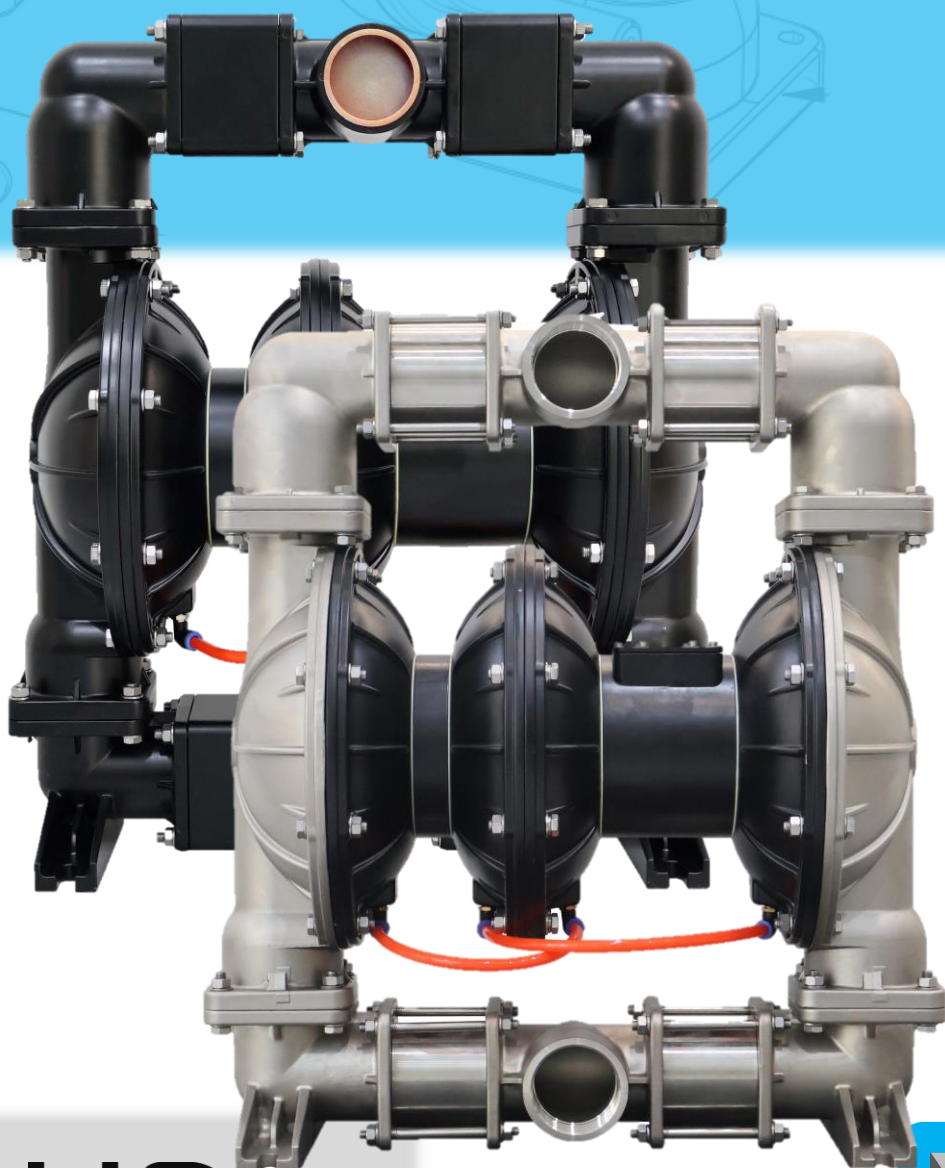

M50HP



Performance Curve

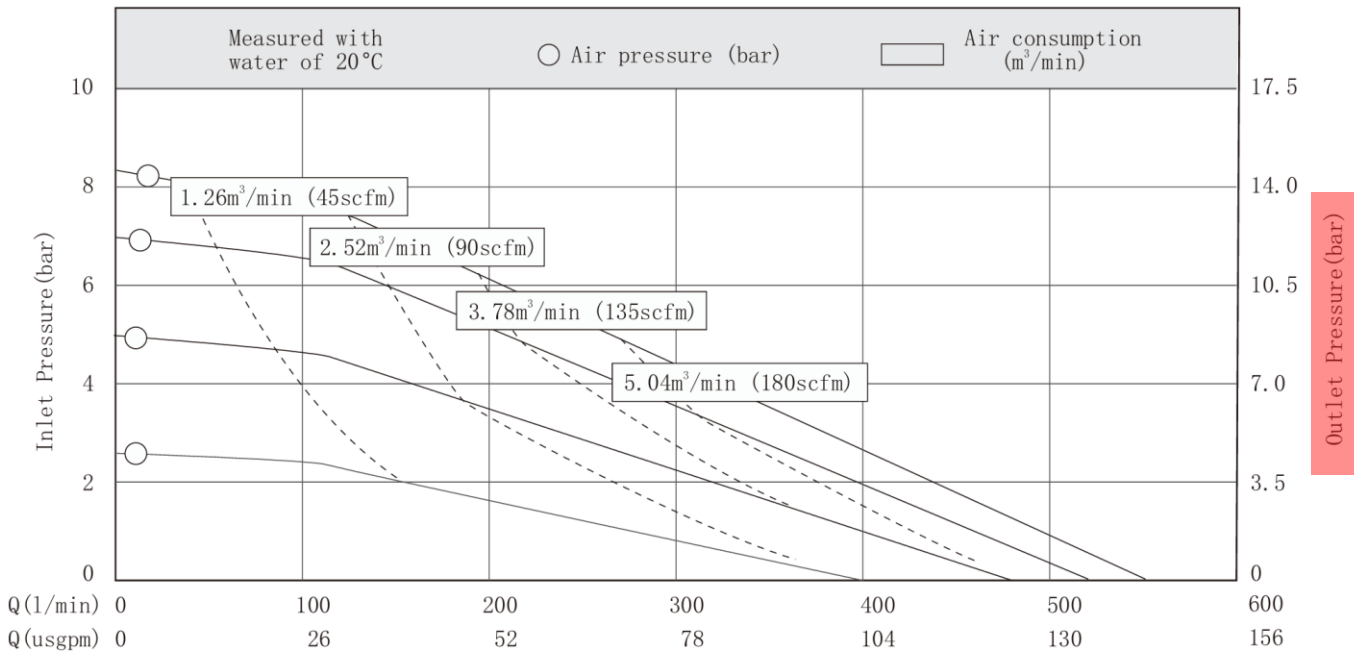

Technical Parameters

Parameter	Unit	Value
Suction Lift - dry	mwc	4
Suction lift - wet	mwc	8
Solids size	mm	5
Air inlet	inch	1/2
Max air inlet pressure	bar	8.4

Material of Construction

Pump Part	Material
Pump body	SS, AL
Diaphragm	Two-piece Teflon
Seat	SS, AL
Centre block	AL

Weight

Pump type	Weight
Stainless 316	62kg
Aluminium	36kg



Dimensional Drawings: Aluminium

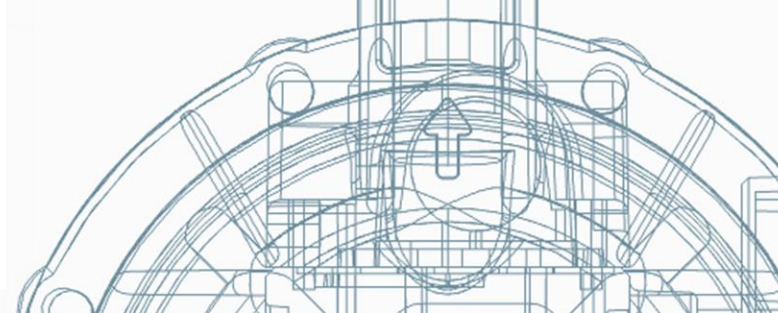
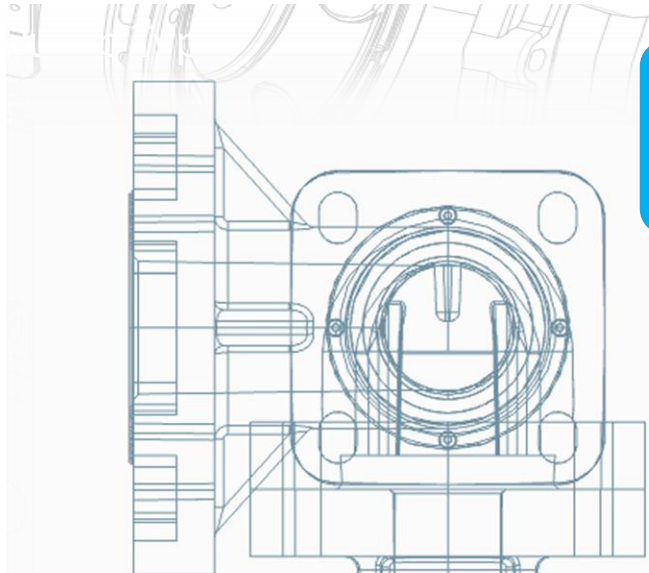
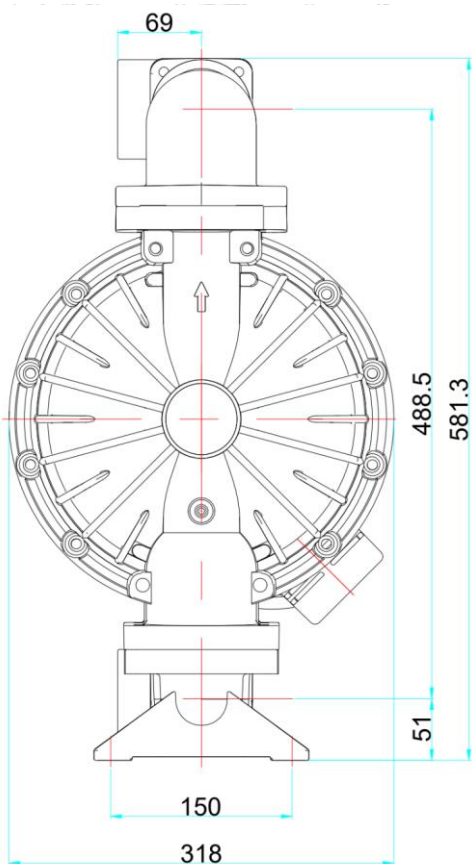
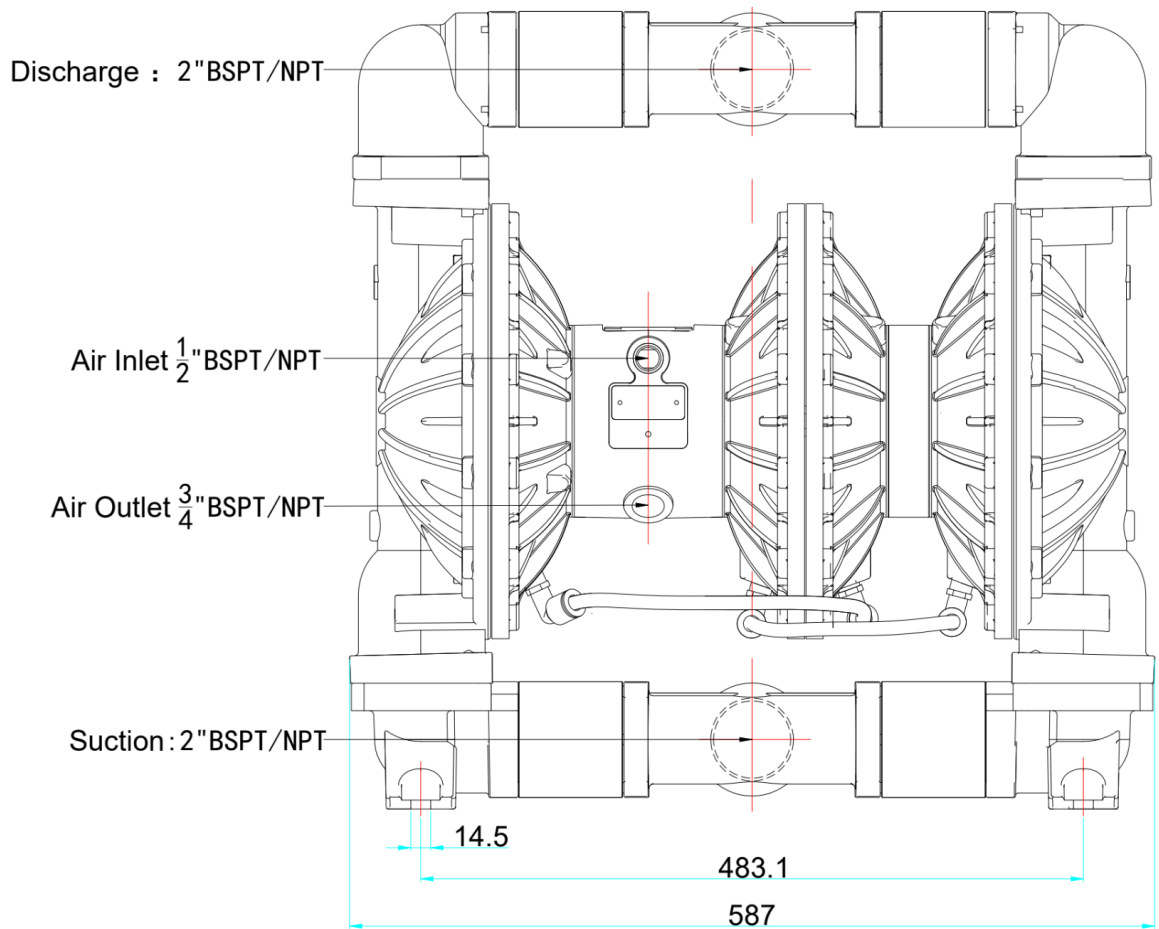

Dimensional Drawings: Stainless

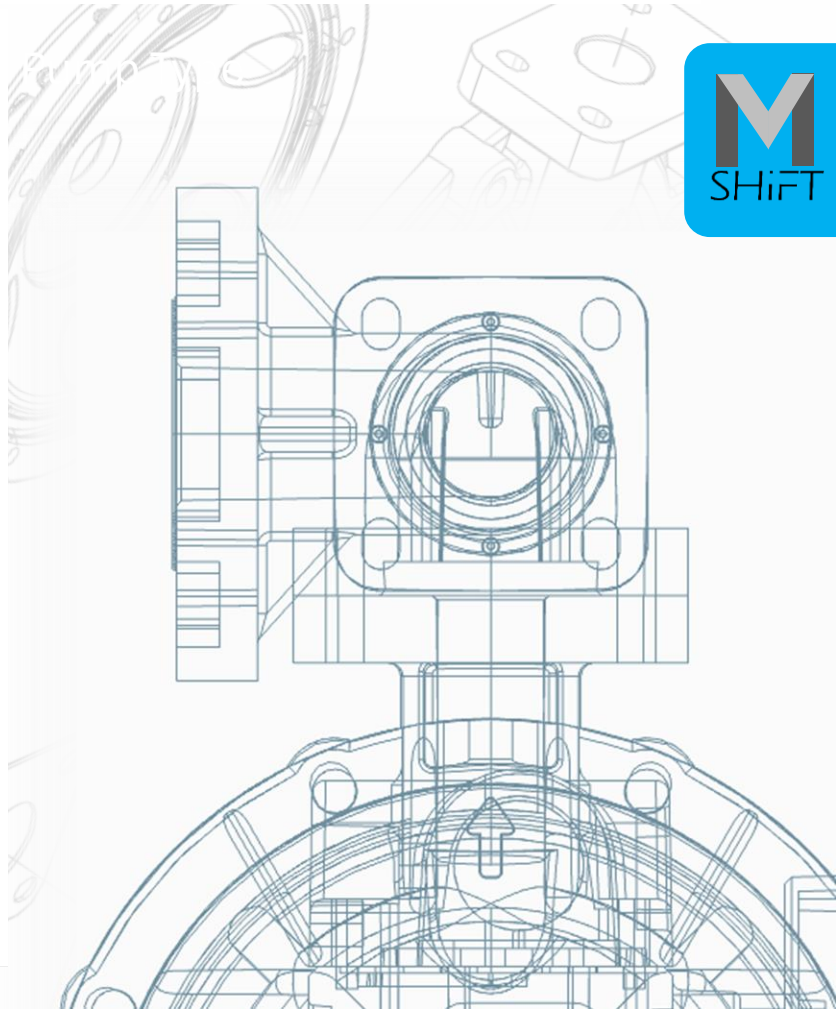
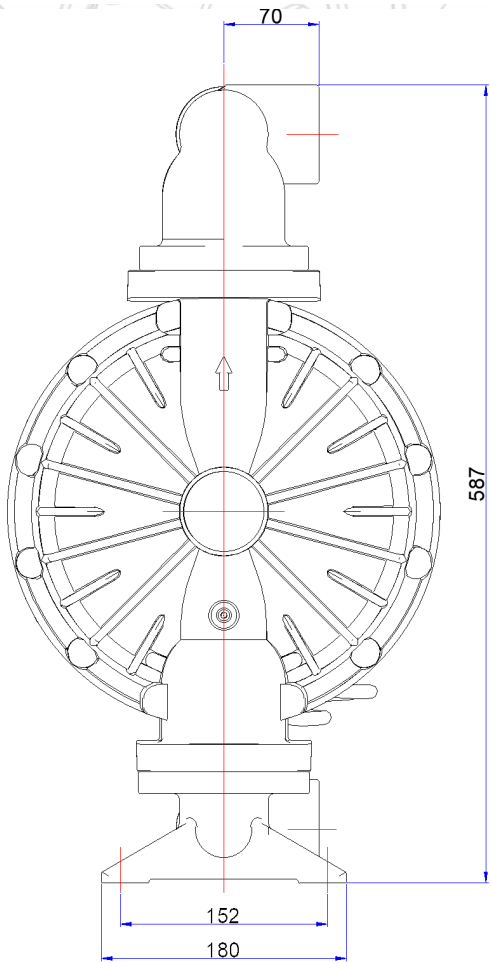
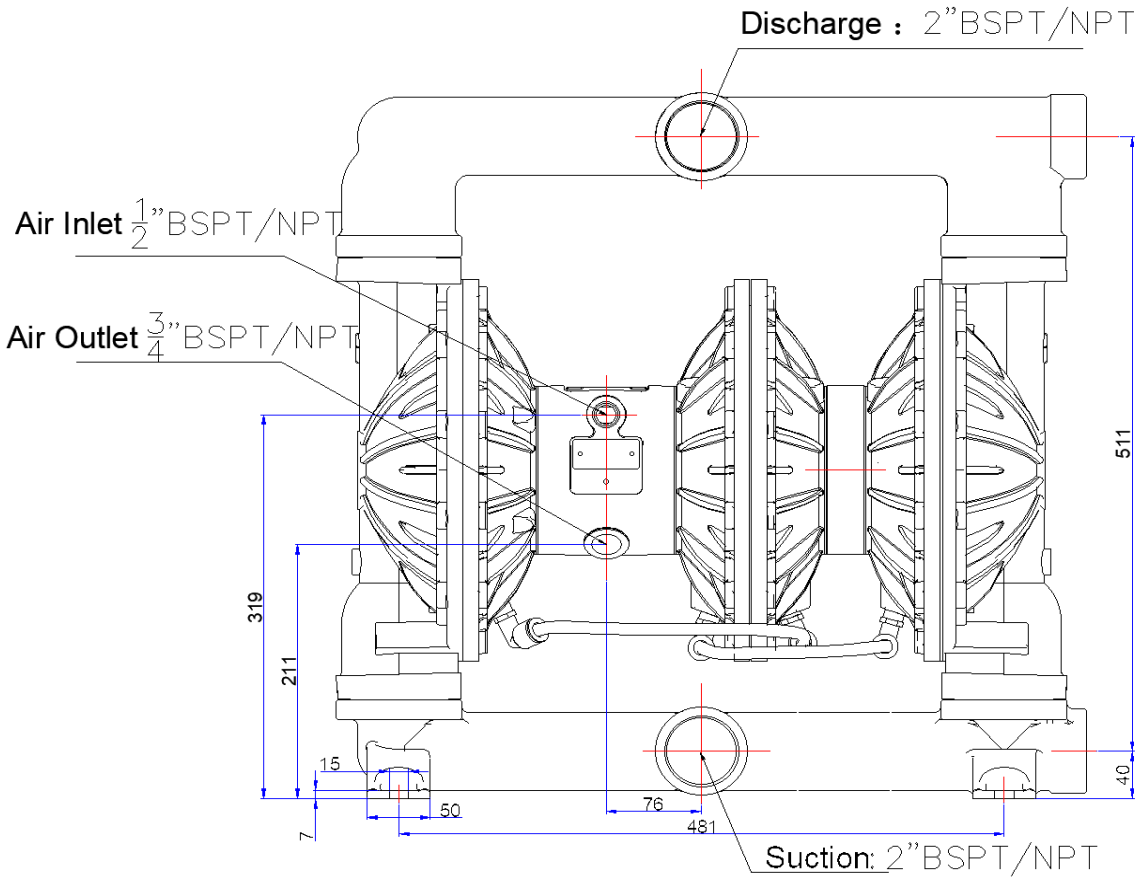

Dimensional Drawings: Stainless

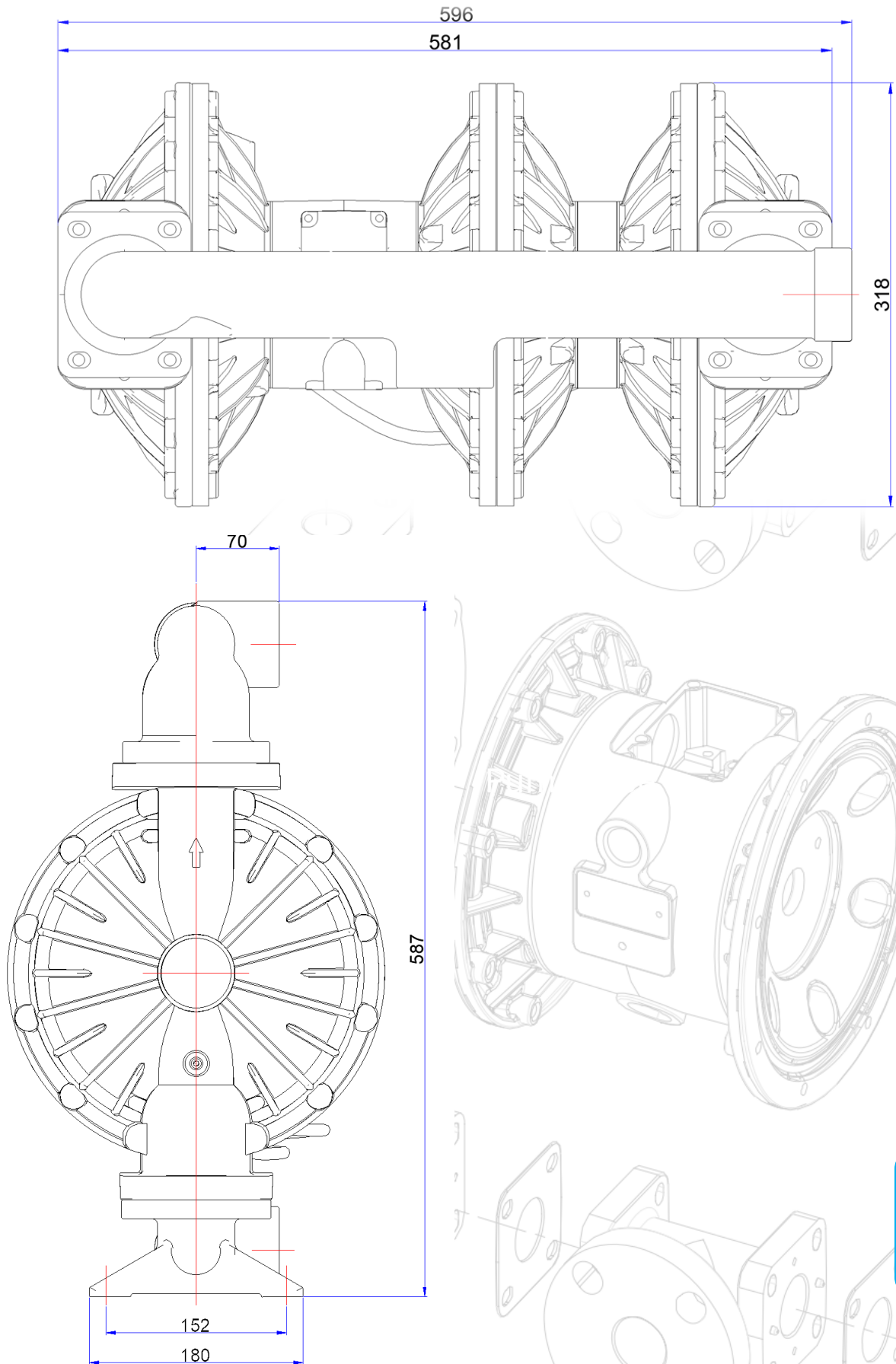

MODULUS

RANGE

Powered by:

Powered by:  **AQS**
INDUSTRIES