



SHiFT[®]

MODULUS

Data Sheet

Full
Flow
High
Pressure
Pumps



M40HP



Performance Curve

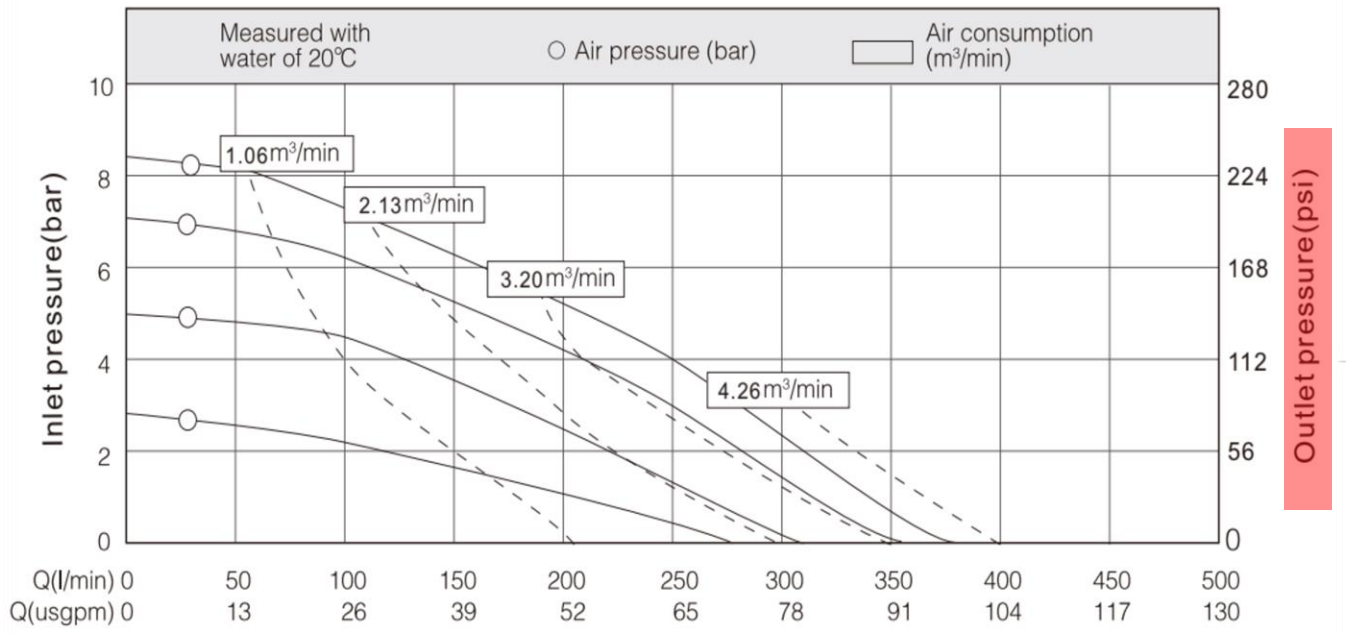

Technical Parameters

Parameter	Unit	Value
Suction Lift - dry	mwc	4
Suction lift - wet	mwc	8
Solids size	mm	5
Air inlet	inch	1/2
Max air inlet pressure	bar	8.4

Material of Construction

Pump Part	Material
Pump body	SS, AL
Diaphragm	One Piece Teflon
Seat	SS, AL
Centre block	AL

Weight

Pump type	Weight
Aluminium	26kg
Stainless	40kg



Dimensional Drawings: Aluminium

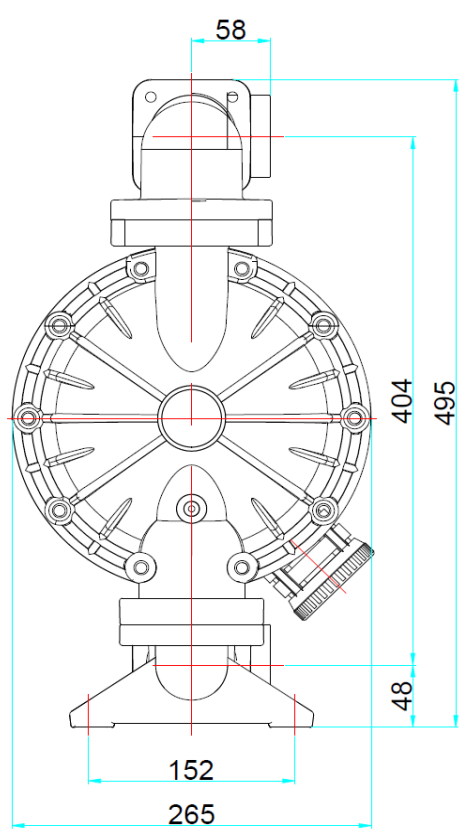
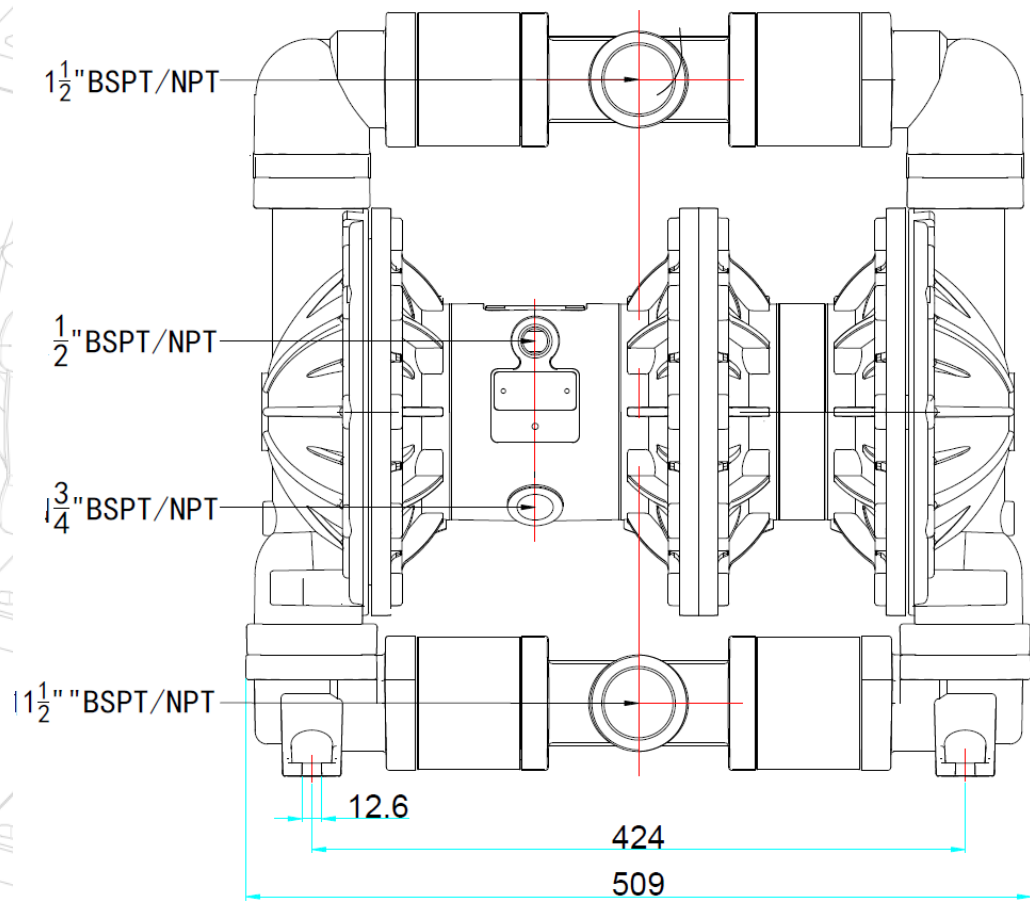

Dimensional Drawings: Stainless

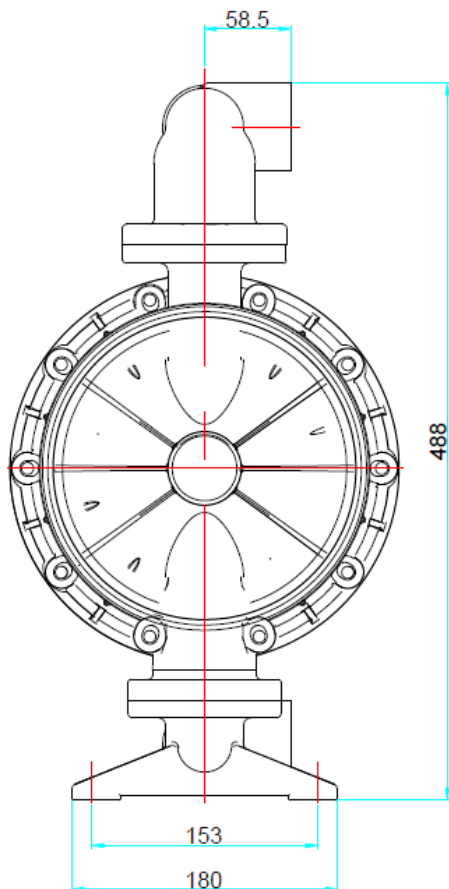
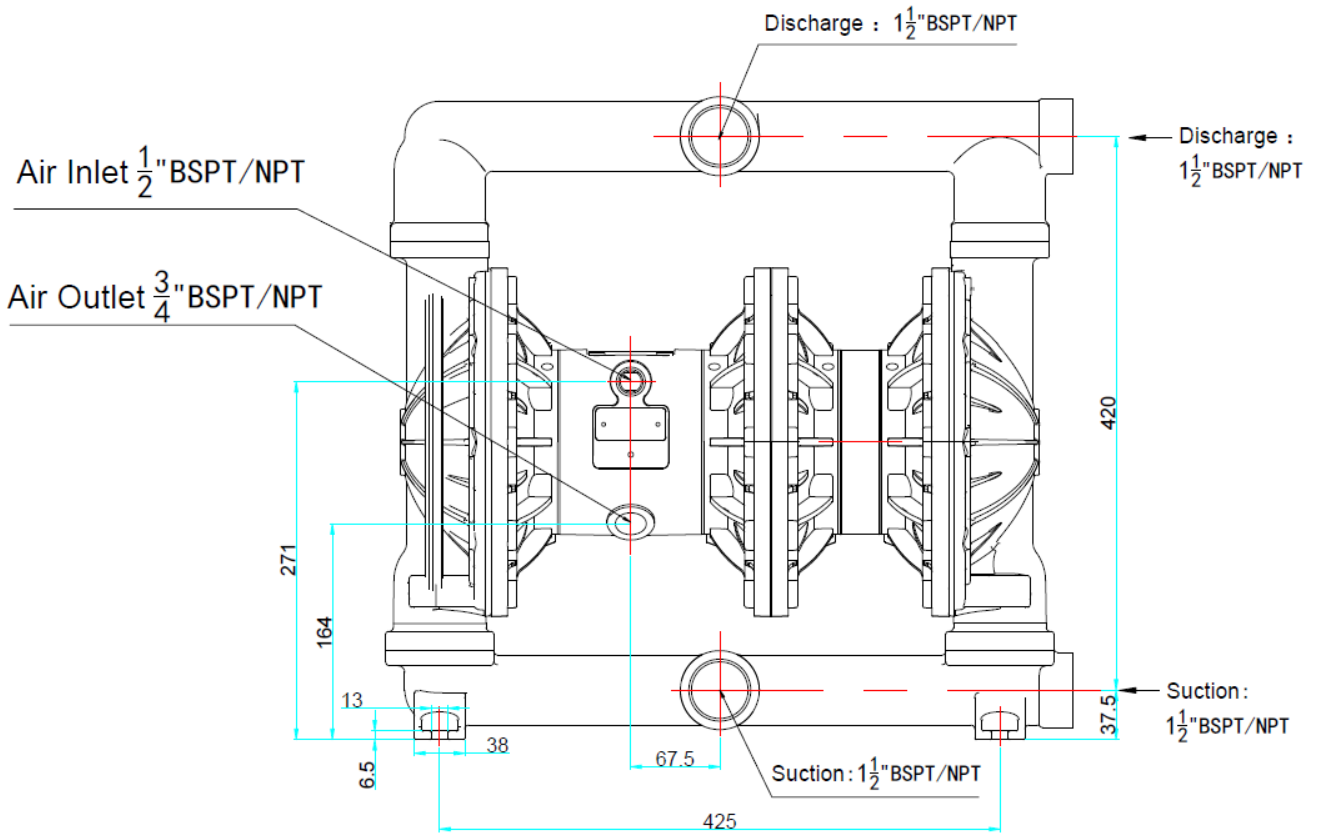



MODULUS

RANGE

Powered by:

Powered by:  **AQS**
INDUSTRIES