

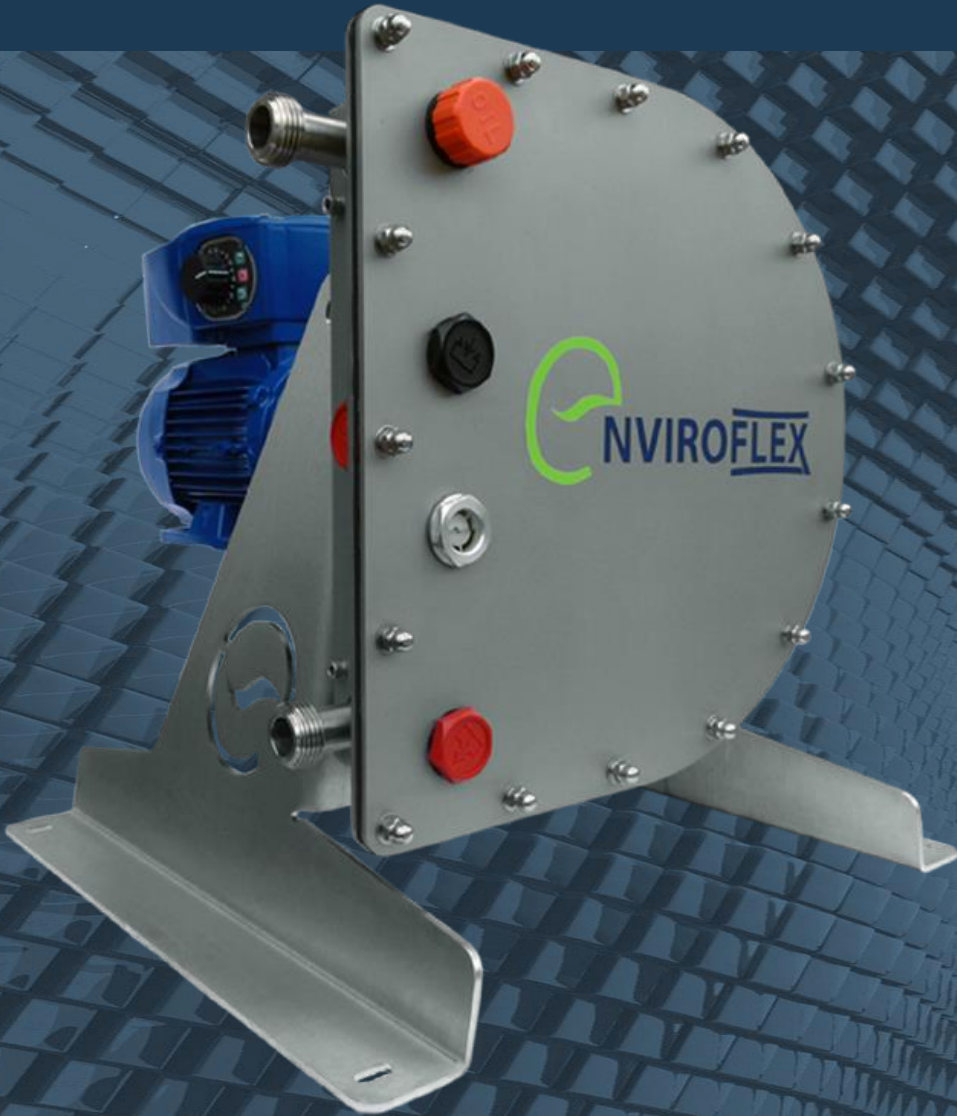

L-SERIES PERISTALTIC PUMPS AND REINFORCED HOSES



www.aqspumps.co.za

L-Series Hose Pumps

An innovative pump range designed to maximise hose life...

The Enviroflex® L - Series pumps and hose deliver all of these benefits helping you achieve maximum efficiency with a cost effective solution.



Significantly lower life cycle costs



Reduced power consumption



Increased productivity



Up to twice the hose life



Ease of serviceability



Operator safety

- Enviroflex® L - Series pump sizes range from 10mm to 150mm.
- Precision ground and wrapped reinforced hose is available for all major brands of hose pump manufacturers and is offered in the following rubbers; natural, nitrile, EPDM, CSM and FKM Food grade options include; natural, nitrile (white liners) and EPDM (blue liner).

ENVIROFLEX®

L - SERIES PERISTALTIC PUMPS AND REINFORCED HOSES



www.aqspumps.co.za

World Class Design

...results in a superior pump

Unique hinged door
eliminates the risk of injury - enables one person to open the pump casing.

Internal hose connector
means pipe work is not required to be dismantled during hose replacement. Dramatically reduces downtime.

Soft action rotating rollers
minimize surface friction, reducing energy consumption and maximizing hose life.

Precision ground hose
improves operational efficiency.

Envirolube lubricant
addresses a broad range of temperature requirements.

Rugged mounting frames
in corrosion resistant materials provide flexibility for port orientation in four directions.

Optional leak detector
automatically stops the pump if a leak occurs

ENVIROFLEX

AQS
INDUSTRIES

www.aqspumps.co.za

Peristaltic Pump & Hose Solutions

...provides accuracy in flow rates

Advantages of the Enviroflex® L - Series Peristaltic Hose Pumps



Energy savings - lubricated rollers utilize lower absorbed power per litre pumped



Large displacement volume ensures greater flow per revolution at slower speeds



Precision ground hose ensures optimum hose life and accurate flow control



Ideal for handling abrasive and viscous liquids



Broadest industrial range of hose materials - CSPE, EPDM, natural rubber, nitrile

Pump Model	Maximum Continuous Speed (RPM)	Maximum Intermittent Speed (RPM)	Maximum Pressure BAR (PSI)	Maximum Continuous Flow Rate LPH (US GPM)	Maximum Intermittent Flow Rate LPH (US GPM)
L10	70	100	7.5 (109)	210 (0.92)	300 (1.32)
L15	70	100	7.5 (109)	420 (1.85)	600 (2.64)
L20	90	100	10 (145)	1242 (5.5)	1380 (6.1)
L25	90	100	10 (145)	2214 (9.8)	2460 (10.8)
L32	70	80	10 (145)	3990 (17.6)	4560 (20.1)
L40	60	90	10 (145)	6552 (28.9)	9829 (43.3)
L50	50	80	10 (145)	10380 (45.7)	16600 (73)
L65	45	60	10 (145)	19170 (84)	25560 (113)
L80	35	50	10 (145)	25893 (114)	36990 (163)
L100	30	40	10 (145)	46800 (206)	62400 (275)
L150	25	35	10 (145)	105000 (462)	147000 (647)

Notes

- Actual flows achieved may vary due to changes in temperature, viscosity, inlet and discharge pressures and/or system design
- Maximum process fluid temperature range is -4° F to + 175° F (-20° C to +80° C)

Enviroflex® Hose Pumps

Markets & Application



Pulp & Paper



Waste Water Treatment



Mining



Food & Beverage



Wine Industry



Marine

	Markets					
	Food, Beverage & Brewery	Marine & Commercial Fishing	Mining & Construction	Waste Water	Pulp, Paper & Wood Products	Utilities & Nuclear Power
Activated Sludges and Slurries			✓	✓	✓	
Chemical Feed	✓		✓	✓	✓	✓
Filtration / Diatomaceous Earth	✓		✓	✓		✓
Fish Processing	✓	✓				
Food Processing	✓					
Grout / Wall Board Compounds			✓			
On-Site Generated NaOCl Feed				✓		✓
Paper Coating					✓	
Polymer Flocculent Feed			✓	✓		✓
Silicone / Caulking Materials			✓			
Scum Pumps / Oil and Waste Sumps			✓	✓	✓	✓
Tanker Off-Loading and Bilge Pumping		✓				
Waste Slurry Transfer	✓		✓	✓		✓
And Many More...	✓	✓	✓	✓	✓	✓

Product Dimensions & Weight

Pump Model	Weight		Dimensions L x W x H (cm)	Dimensions L x W x H (in)	Standard Connections
	kgs	lbs			
L10	30	66	35 x 26 x 49	14 x 10 x 20	3/8" BSP/NPT MALE
L15	30	66	35 x 26 x 49	14 x 10 x 20	1/2" BSP/NPT MALE
L20	65	143	51 x 50 x 54	20 x 20 x 21	3/4" BSP/NPT MALE
L25	65	143	51 x 50 x 54	20 x 20 x 21	1" BSP/NPT MALE
L32	155	342	69 x 62 x 72	27 x 24 x 29	1-1/4" BSP/NPT MALE
L40	250	551	86 x 70 x 86	34 x 28 x 34	1-1/2" BSP/NPT MALE
L50	300	661	86 x 70 x 86	34 x 29 x 39	2" BSP/NPT MALE
L65	375	827	107 x 89 x 114	42 x 35 x 45	2-1/2" BSP/NPT MALE
L80	540	1190	124 x 94 x 132	49 x 37 x 52	3" BSP/NPT MALE
L100	902	1984	148 x 146 x 165	58 x 57 x 65	4" VICTAULIC
L150	1804	3968	216 x 203 x 216	85 x 80 x 85	6" VICTAULIC

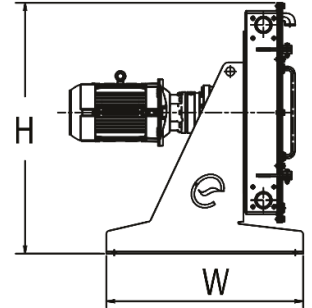
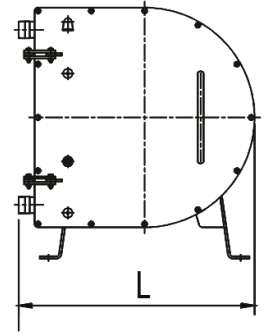

High precision replacement compatible peristaltic hose, shoes, rollers, shims, seals, lubricant and hose clips.

Compatible with the following manufacturers:

Abaque, Albin, Boyser, Bredel, Blackmer, Delasco, Elro Crane, Envirotech, Flowrox, Graco, King Cobra, LSM, Mouvex, PCM, Periflo, Ponndorf, Rosewater, Redbaron, Relax, Verderflex, Wanna Vector, Watson Marlow and all OTHER makes of peristaltic pumps.





**UNIVERSALLY COMPATIBLE
PERISTALTIC HOSES
5mm – 150mm**

**AVAILABLE IN EPDM / NITRILE / HYPALON & NATURAL
RUBBER**



www.aqspumps.co.za